

TB217R
1.7-TONNE



**COMPACT MINI
EXCAVATOR**

SHORT TAIL SWING

takeuchi[®]
From World First to World Leader

TB217R short tail mini excavator

The TB217R canopy is a compact mini excavator designed for maximum accessibility and trailer towing.

The TB217R features a longer than average track frame for added stability (1570mm). With excellent working ranges for a 1.7-tonne weight class; maximum dig depth 2390mm and dump height 2545mm.

The TB217R is a versatile mini that works in the tightest spaces with a very short slew radius of just 730mm. An excellent alternative for plant and tool hire, utilities, light landscaping and jobbing builders.

The TB217R combines all the proven characteristics of Takeuchi excavators: smooth hydraulics and power performance, proven durability and high resale value, maximum operator comfort and serviceability.

STAGE V ✓
<19kW READY



ROBUST FOR SITE

The fabricated steel boom and arm provide maximum strength.

The top mounted hydraulic cylinders and internally routed hoses provide added on-site protection.

Site safety with all steel roof canopy and lifting points.



EXPANDABLE TRACK FRAME

A unique hydraulic expanding track frame adjusts from 980 to 1300mm.

The expanded width and the longer track frame gives greater operating stability. Extendable dozer blade with quick bolt-on extensions as standard.





EASY ACCESS & MAINTENANCE

The full width service door gives greater access for service, cleaning and maintenance, with hinged, all steel lockable panels.

Clustered, fuel, air and oil filters minimise service and daily check times. A removable floor plate for greater access to the hydraulic control valve and piping.

Triple flanged track rollers and easy adjust track tension with grease filled track adjusters, gives reliable track retention.

COMPATIBLE BREAKER

The TB217R is compatible with a Takeuchi TKB52-S sound suppressed hydraulic breaker. Designed to meet the requirement for quieter operating environments.



EASY TO OPERATE & SHORT TAIL SWING

Pilot controls combined with cushioned boom and swing cylinders, help reduce shock and vibrations for a smoother machine operation.

The breaker auxiliary is foot pedal operated.

The TB217R gets into very tight spaces with a slew radius of 730mm. Works close to walls and has just 70mm overhang at 90° to extended track.

STANDARD FEATURES

(see website for the complete features list)

OPERATOR STATION

- All steel Canopy (ROPS/ TOPS/ OPG) with integrated roof lift points
- Adjustable seat with retracting seat belt
- Adjustable armrests
- Multi information display
- Key locked access panels
- Foot rests, offset and auxiliary food pedal

ELECTRICAL

- Power Socket - 12V
- Sealed rocker switches
- Travel alarm
- Workzone lights
- Enhanced VDU

ENGINE

- Stage V <19kW engine - low emission
- Dual fuel filtration with water trap
- Dual element air filters
- Easy access service check points
- Service interval - 250 hours



HYDRAULICS

- Variable displacement piston pumps
- Cushioned boom and swing cylinders
- Top mounted boom cylinder
- Well protected internally routed hydraulic hoses
- Easy access 1-way/ 2-way flow selector valve below the operator seat
- Aux with independent isolation valves
- Steel hydraulic tank with fluid level sight gauge
- Aux ports: 1st standard, 2nd & 3rd optional

UNDERCARRIAGE AND FRAME

- Retractable track frame 980-1300mm
- Load sensing two speed travel auto shift
- Longer than average track frame for added stability (1570mm)
- Triple flanged track rollers & sealed bearings
- Adjustable width dozer blade with on-board bolt-on extensions.



TSS - TAKEUCHI SECURITY SYSTEM

The TB217R comes with TSS as standard. Includes 1 red master key and 3 black user keys. Can programme up to 13 user keys.



PROTECTED BY
TAKEUCHI
SECURITY
SYSTEM

TB217R SHORT TAIL SWING EXCAVATOR

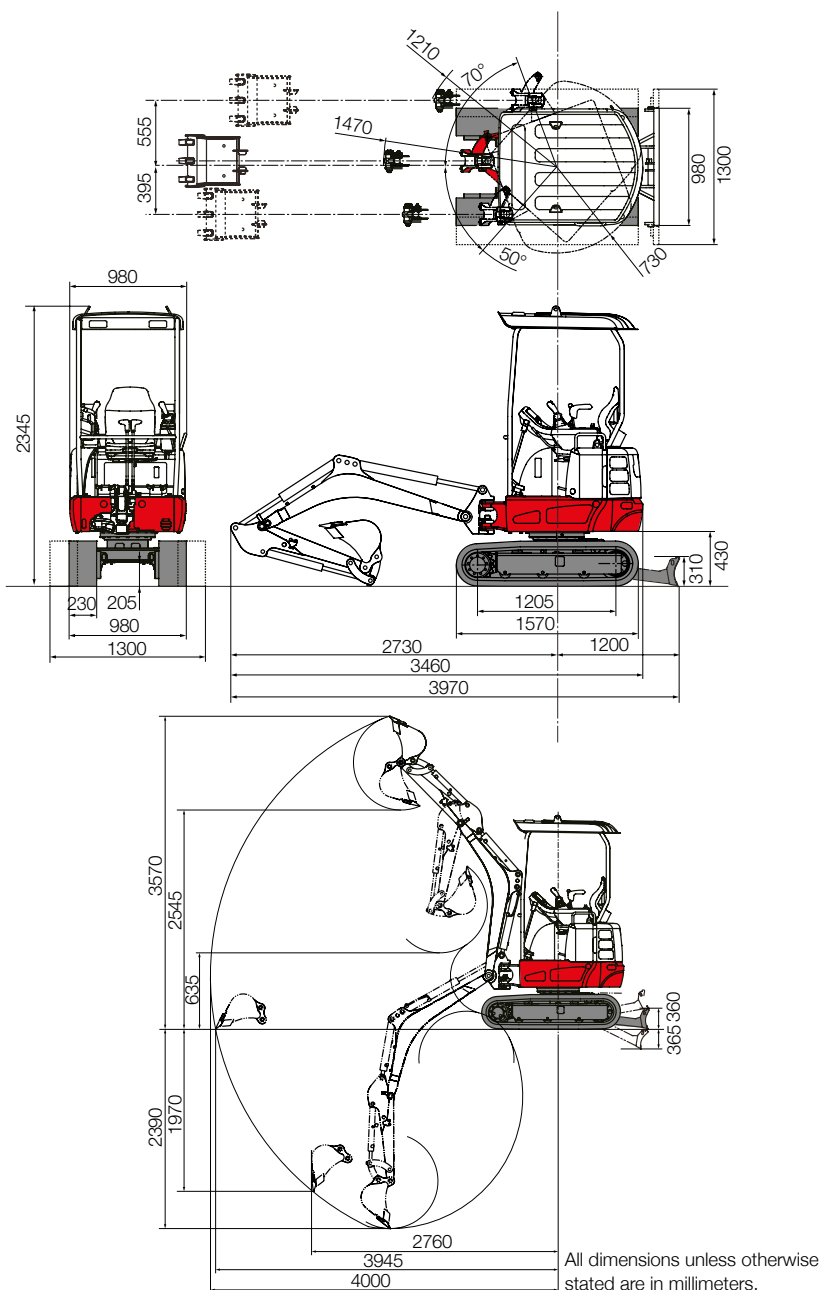

TB217R

Standard UK Specification - Long Arm / Rubber Tracks

Engine	
Make	YANMAR
Model	3TNV70
Rated Output (kW)/rpm	11.5 / 2400
Maximum Torque (Nm)	52.6
Cylinders	3
Displacement (cc)	854
Electrical System	12v 48A

Dimensions & Weight	
Op. Weight (bucket, hitch, fuel) kg	1680
Overall Length (mm)	3460
Overall Length dozer at rear (mm)	3970
Width (mm)	980
with extended track (mm)	1300
Height (mm)	2345
Ground Clearance (mm)	205
Min. Front Swing Radius (mm)	1470
Slew Radius (mm)	730
Dozer Blade (W x H) (mm)	980/1300 x 310

Operating Information	
Max Digging Depth (mm)	2390
Max Dump Height (mm)	2545
Max Reach at Ground Level (mm)	3945
Max Vertical Digging Depth (mm)	1970
Max Bucket Digging Force (kN)	14
Max Arm Digging Force (kN)	8.2

Hydraulic System	
Main System Pressure (bar)	210
Pump Type	Variable x 2 + Gear x 2
1st Auxiliary Maximum Flow (l/min) / Pressure (bar)	33 / 210
*2nd Auxiliary Maximum Flow (l/min) / Pressure (bar)	10 / 200

Swing System	
Boom Swing Angle (L/R)	70° / 50°
Slew Speed (rpm)	9.2
Slew Motor	Trachoid Gear
Slew Brake	Wet Friction Plate

Undercarriage	
Traction Motor	Axial Piston
Traction Drive	Planetary
Traction Brake	Disc
Track Width	230
Ground Contact Length (mm)	1205
Ground Pressure (kpa)	27
Travel Speed (km/h)	2.2-4.2
Maximum Gradeability	15°

Capacities	
Hydraulic System (l)	24
Fuel Tank (l)	22
Engine Lubrication (l)	2.8
Cooling System (l)	3.9

Health & Safety	
Noise / Sound Power Level (LwA)	93 dB
Vibration Hand Arm / Body m/sec ²	≤2.5 / ≤0.5

**2 YEAR
2,000 HOUR**

WARRANTY*

Takeuchi machines come with a 2 year/2000 hours warranty as standard. Before fitment of a hydraulic attachment, machine auxiliary pressure and flow should be accurately measured.

In accordance with our established policy of constant improvement, we reserve the right to amend these specifications at any time without notice. Photographs shown may feature non-standard equipment.

11/2023

For more information locally contact:



SCAN ME

To find your local dealer

Takeuchi Mfg (UK) Ltd, Unit E2B Kingsway Business Park, John Boyd Dunlop Drive, Rochdale, Lancashire OL16 4NG
info@takeuchi-mfg.co.uk www.takeuchi-mfg.co.uk

@TakeuchiUK

TAKEUCHI
From World First to World Leader